

KPC-3+
Telemetry Input
and
Control Output
Standardization Document
for
Oregon Coast Repeater Group
APRS Digi-peaters
and
Network Nodes

Version 20041226.1

December 26, 2004

Paul Messer, WA7ZVY

Change Log

Date of change:	Subject of change:
April 1, 2004	Initial file creation
April 15, 2004	Major additions and changes to entire doc
December 9, 2004	External Telemetry Adapter added
December 12, 2004	Control Output text added
December 26, 2004	External Control Adapter pictures added

Table of Contents

1. Telemetry Inputs on KPC-3+	4
2. Telemetry Range Control	4
3. Pre-wired Analog Telemetry Inputs	4
4. Patch Wired Telemetry Inputs	5
5. Digital Only Telemetry Inputs	5
6. Telemetry UI Frame	5
7. Telemetry Input Wiring Configuration Table	6
8. Control Outputs on KPC-3+	7
9. Telemetry Input and Control Output Schematic Diagram	8
10. System Level Diagram	9
11. Telemetry Breakout Adapter	10
12. DB-25 Terminal Connector Pin-out	12
13. Control Breakout Adapter	13
14. PCB Layout for Attenuator Board	14

1. Telemetry Inputs on KPC-3+

There are five analog telemetry inputs possible on the KPC-3+. However, of these five inputs, only two of them are connected to the external input connector pins in an off-the-shelf stock KPC-3+. The other three inputs must be internally patch wired to an external connector to make them available for external usage.

The analog telemetry inputs, to the KPC-3+'s CPU, are limited to an input voltage range of 0.0 volts to 5.0 volts. Therefore, to monitor devices or functions that have a higher voltage range, an attenuating resistive divider must be used. The two pre-wired telemetry inputs have a non-populated resistor location available for each of them, to create the attenuators for those channels.

Also, a single digital only telemetry input is available by using the Data Terminal Ready input signal. This DTR signal is wired, but not used by the KPC-3+'s software. It is, however, reported to the user in the telemetry data UI frame packet.

2. Telemetry Range Control

The later versions of the KPC-3+ software (version 9.0) include a "RANGE" command. This command allows the user to specify how the analog telemetry data will be reported back to the user. The user must still insure that the input signal level stays within the 0.0 volt to 5.0 volt input range. But, by using the "RANGE" command, the user, for example, can specify that a signal going from 0.0 volts to 5.0 volts will report back to the user as 0 to 150. So, for example, if one wanted to measure a 120VDC power supply going from 0 to 150VDC, this would require that an input attenuator with a 30:1 attenuation factor be used. Since it is important to keep the actual voltage levels going into the KPC-3+ at a "safety extra low voltage level" (less than 48 volts, and a lower level is even better), using an external attenuator setup is required. One possible solution would be an external 100k-ohm ½ watt input resistor with an external 3450-ohm pull-down resistor. (However, the input leakage current needs to be factored into any high value resistor usage, as it could significantly affect the accuracy of the sampled signal). No internal pull-down resistor would be used inside the KPC-3+ with this example external attenuator arrangement.

3. Pre-wired Analog Telemetry Inputs

The two pre-wired telemetry inputs could be input on either the DB-9 radio port or the DB-25 terminal port. For consistency, and to keep these input signals independent of the control output signals (see Section 9 on page 8), it is recommended that the inputs be setup to use the DB-25 terminal connector input. This way, both the pre-wired inputs and the patch wired inputs would all be on the same DB-25 terminal port connector. The information in the configuration table shows the positions to move jumpers to achieve this setup.

Two resistor positions are available at R13 & R27 to act, along with the two 10k ohm input resistors R18 & R24, as an attenuator to allow higher voltage levels to be input into the telemetry inputs. If these resistors locations (R13 & R27) are populated with 2.4k ohm resistors, this will cause the scale for each input to be set such that the telemetry channel will read in 0.1V steps to produce a reading of 050 for a 5V input signal and 120 for a 12V input signal, for example. (The resistive divider is made up of a 10k ohm input resistor with the 2.4k-ohm resistor going to ground). This type of an arrangement might be useful for KPC-3+ units with older software that do not support the "RANGE" command.

4. Patch Wired Telemetry Inputs

To use the other three telemetry channels, a small circuit board is constructed with positions for attenuator resistors, zener protection diodes, and small filter capacitors. This small circuit board is sized such that it will fit into the hole that the optional 9V battery utilizes. This small circuit board is wired to the P2 connector (to allow external access) and to the CPU integrated circuit for the actual A/D input signals.

5. Digital Only Telemetry Inputs

There is one binary only telemetry input available. This input is the DTR signal input on the DB-25 terminal connector, P2-20. The KPC-3+ manual states, "Although interconnected via a buffer IC to the processor, this line is currently ignored." The high or low state of the DTR input signal is reported in bit 7 of the telemetry binary values ($b_7 b_6 b_5 b_4 b_3 b_2 b_1 b_0$). Note: The buffer in this pin's path is an inverter, so the reported signal will be inverted from the actual input level.

The five analog telemetry inputs may also be used for binary data inputs. Their state is also reported in the telemetry binary values ($b_7 b_6 b_5 b_4 b_3 b_2 b_1 b_0$). The reported signal levels for these five signals are NOT inverted. Note: It may be necessary to remove the pull-down scaling resistor, on the input, to achieve satisfactory signal levels for proper detection of logic 1 levels from typical TTL, LVTTTL, or LVCMOS devices.

6. Telemetry UI Frame

A telemetry UI frame reports as:

T#nnn,an0,an1,an2,an3,an5, $b_7 b_6 b_5 b_4 b_3 b_2 b_1 b_0$

Where:

- nnn is a decimal sequence number that cycles from 000 to 999 and increments upon each transmission of the telemetry frame. At count 999 it returns to 000 on the next increment.
- an0,an1 are the analog telemetry values from the pre-wired telemetry channels.

**KPC-3+ Telemetry Input and Control Output Standardization Document
for Oregon Coast Repeater Group APRS Digi-peaters and Network Nodes**

- an2,an3,an5 are the analog telemetry values for the patch wired telemetry channels.
- b₇ b₆ b₅ b₄ b₃ b₂ b₁ b₀ are the binary reported values for the telemetry port. The most significant bit, b₇, corresponds to the DTR signal level. b₅, b₃, b₂, b₁, b₀ correspond to the binary logic high or low levels of an₅, an₃, an₂, an₁, an₀.

7. Telemetry Input Wiring Configuration Table

The following table shows information related to the connections necessary to configure the AD0 and AD1 pre-wired telemetry channels and to add the A/D Attenuator Board to the KPC-3+ for telemetry input:

Channel	Wire DB-25F Terminal Connector Pin or Internal Connection Point	Add Wire to CPU Pin (note a wire pad is available close to the CPU pin)	Voltage or Function Monitored or Controlled
AD0	Already wired on KPC-3+ PCB. Place jumper on J8 center to pin 2. Connects input to P2-18. Add a 6.0v zener diode at R27 position, anode to ground, cathode to signal line. Add a 2.4K ohm resistor in parallel with the added zener diode.	Already wired on KPC-3+ PCB.	Users choice.
AD1	Already wired on KPC-3+ PCB. Place jumper on J10 center to pin 2. Connects input to P2-11. Add a 6.0v zener diode at R13 position, anode to ground, cathode to signal line. Add a 2.4K ohm resistor in parallel with the added zener diode.	Already wired on KPC-3+ PCB.	Users choice.
AD2	Attenuator Board Pad W1 to P2-12.	Attenuator Board Pad W2 to U5-63 wire pad.	Users choice.
AD3	Attenuator Board Pad W3 to P2-14.	Attenuator Board Pad W4 to U5-65 wire pad.	Users choice.
AD5	Attenuator Board Pad W5 to P3-1 (internal) or P2-19 (external).	Attenuator Board Pad W6 to U5-62 wire pad.	+12V (internal) or users choice (external).
Ground	Connect Attenuator Board Pad WG to GND pad near R33.		

8. Control Outputs on KPC-3+

Two open-drain control outputs are available on the KPC-3+'s radio port, P1. The two control pins are capable of sinking a maximum of 200mA continuously, and 500mA pulsed. The voltage level applied to the control pins must be less than +60VDC and it is highly recommended to limit any voltage level to +48VDC or less. Negative voltage levels are not permitted. The two control pins are controlled with the KPC-3+'s "CTRL" command.

Command syntax is:

`CTRL < A | B > [n | ON | OFF | LONG]`

Where:

< A | B > selects which control output the command will affect, either CTLA or CLTB. If not specified, both the CTLA and CLTB outputs are affected.

[n | ON | OFF | LONG] specifies how to affect the selected control output(s).

n specifies the number of 100 milliseconds pulses to do to the port(s). The valid range is from 1 to 20.

ON specifies to turn on the control output transistor, which will drive the open-drain output to GROUND.

OFF specifies to turn off the control output transistor, which will allow the open-drain output to float, or go to any attached pull-up resistor's positive rail voltage.

LONG specifies to turn on the control output transistor for one pulse lasting 1.5 seconds duration. Note: only one LONG pulse can be generated at a time with the CTRL command.

9. Telemetry Input and Control Output Schematic Diagram

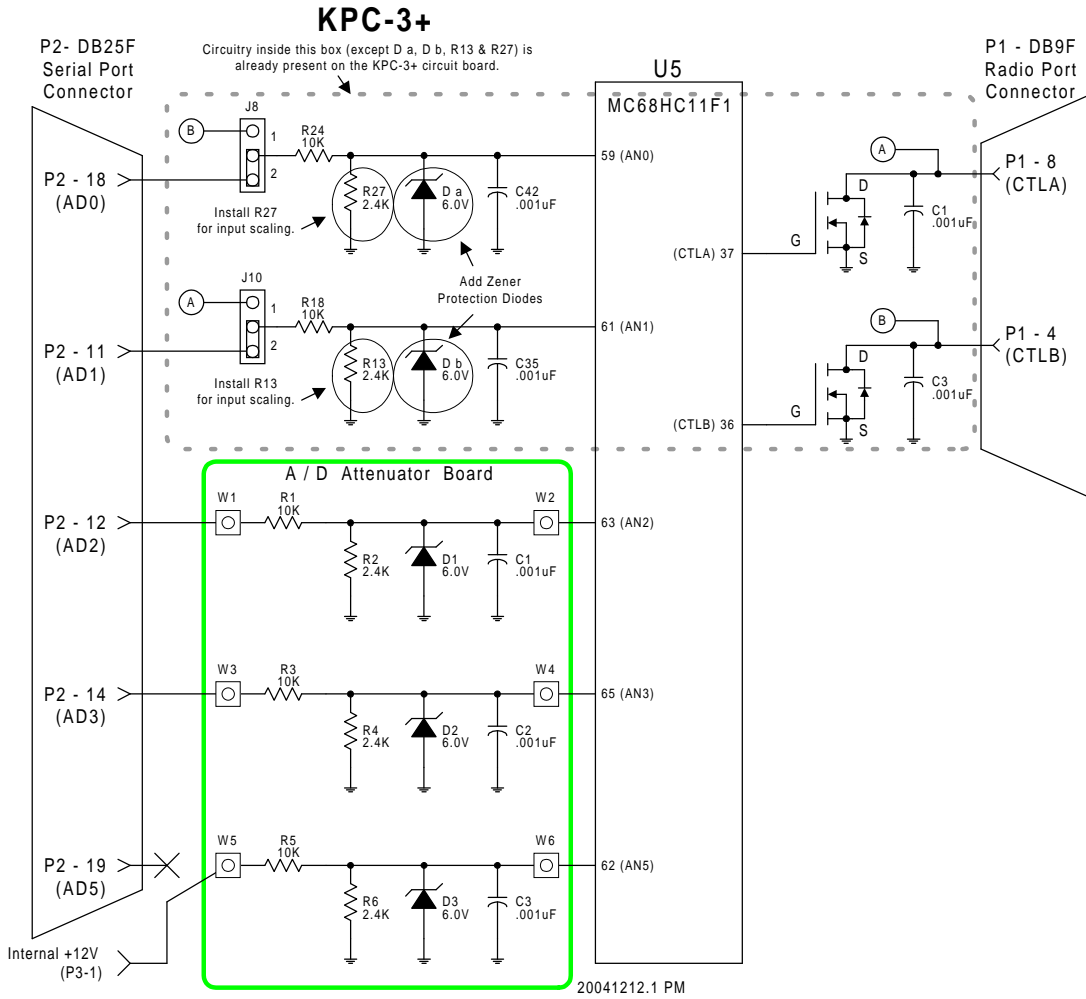

10. System Level Diagram

The system level diagram shows one possible telemetry implementation. This configuration allows the monitoring of power system sources along with the internal power delivery in the KPC-3+. Five inputs and two outputs are available for general monitor and control functions. Note that the two digital control outputs, CTLA and CTLB, are located on the radio port connector, P1.

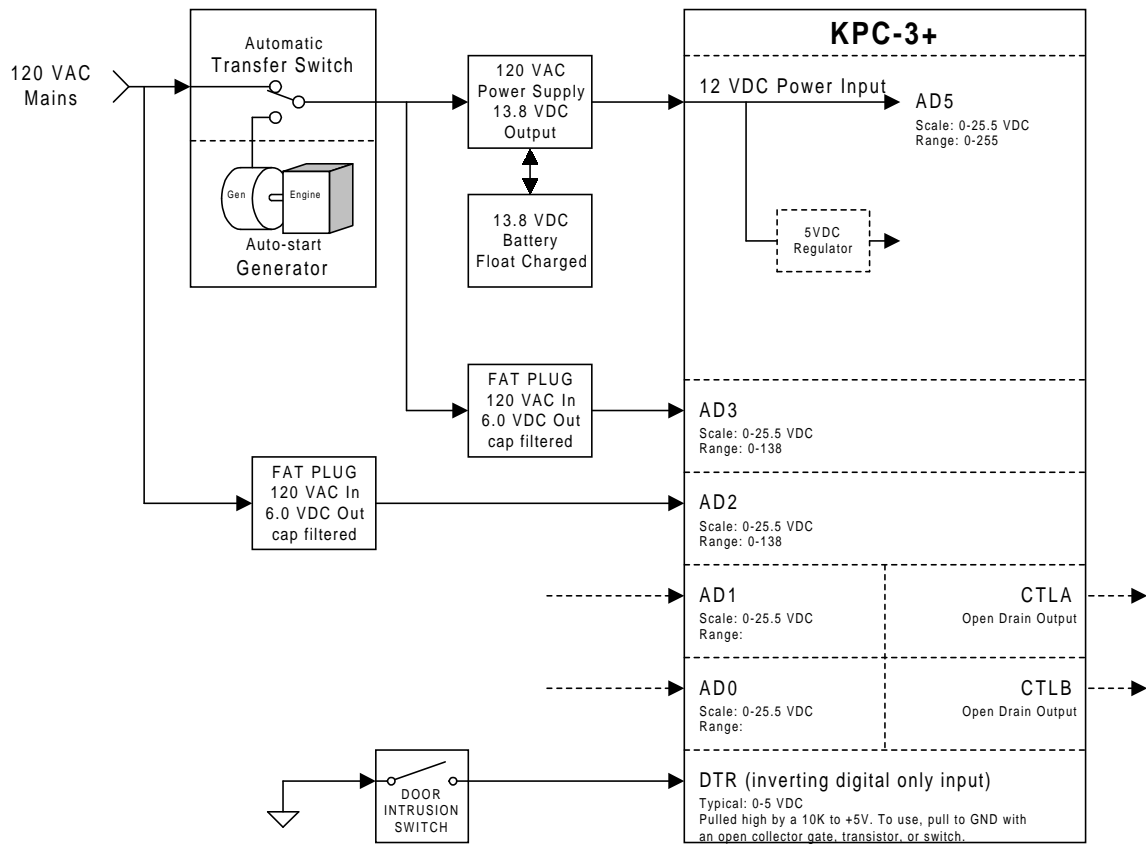

11. Telemetry Breakout Adapter

An external breakout adapter, for the telemetry signals, is constructed with a DB25 male plug, a DB25 female socket and a set of side entry vertical screw terminal strips. This allows easy access to the KPC-3+'s telemetry input signals. The adapter unit is built into a DB25 "in-to-out" adapter housing. The male connector of the adapter is plugged into the KPC-3+'s female DB25 serial port connector (P2); and, any serial device normally used with the KPC-3+ is then plugged into the female DB25 socket on the Telemetry Adapter.

KPC-3+ EXTERNAL TELEMETRY ADAPTER

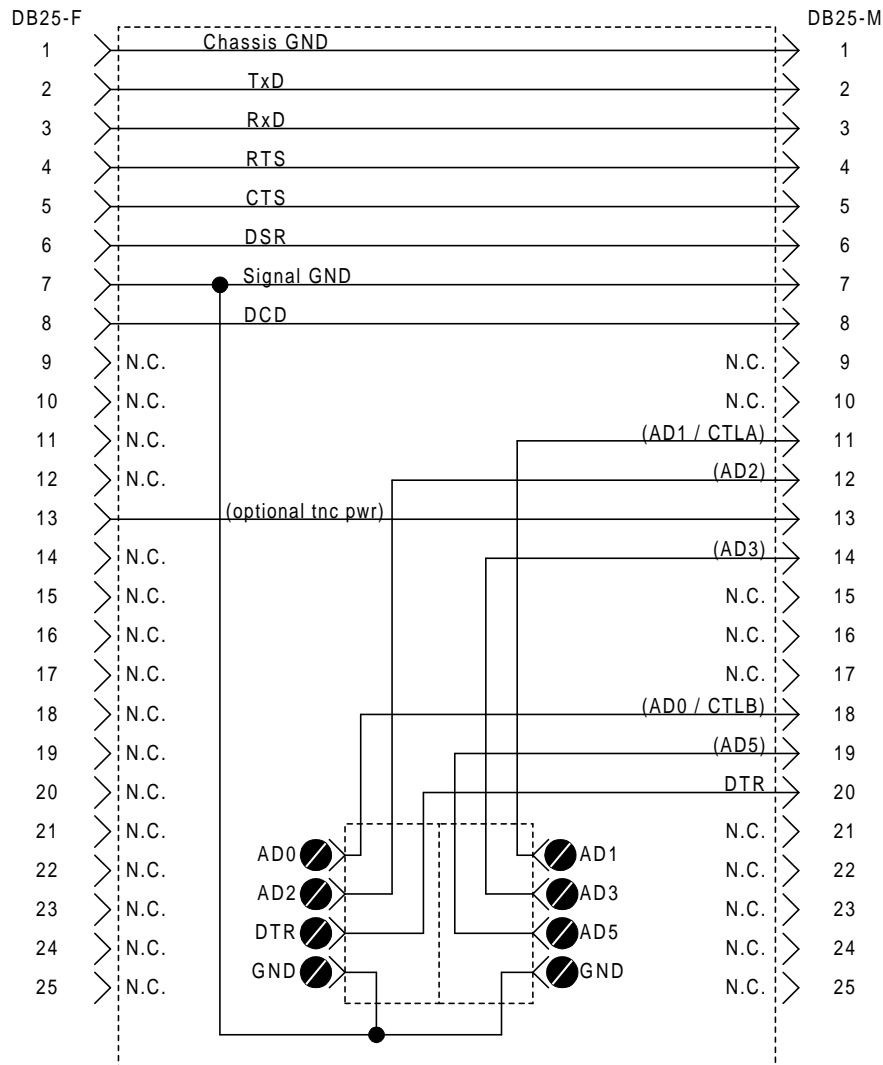

WA7ZVY 20041205.1

**KPC-3+ Telemetry Input and Control Output Standardization Document
for Oregon Coast Repeater Group APRS Digi-peaters and Network Nodes**



Telemetry Breakout Adapter



Telemetry Breakout Adapter

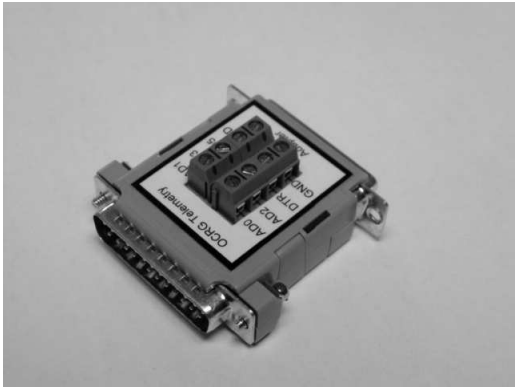

Telemetry Breakout Adapter

12. DB-25 Terminal Connector Pin-out

EIA-232 Industry Standard Pinout

with

KPC-3+ Signal Names (Green),
KPC-3+ Not-used Signals (Blue)

and

Telemetry Input Signal Overlay (Red)
(for reference)

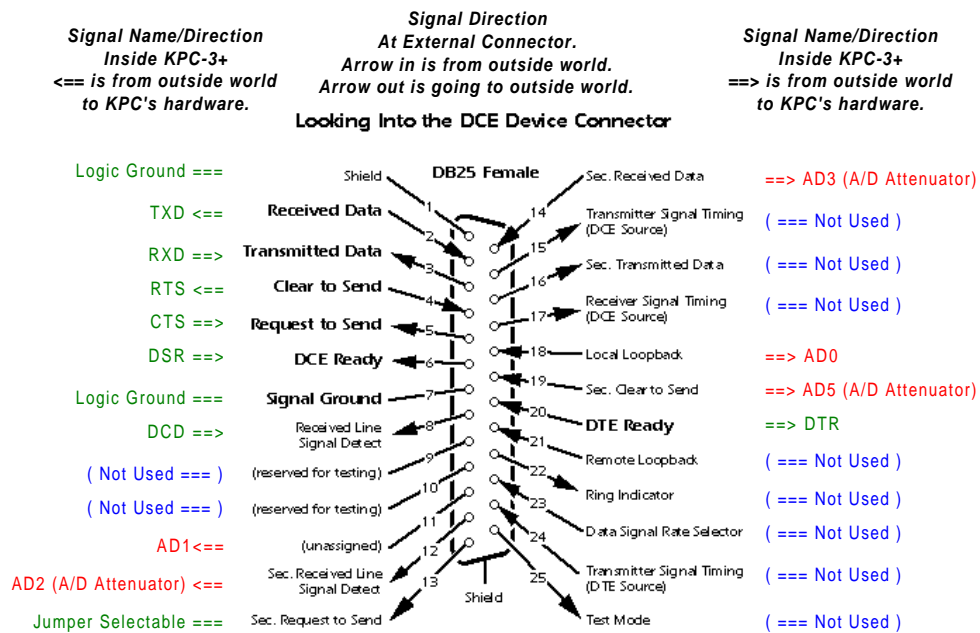

20040401.2 PM

13. Control Breakout Adapter

An external breakout adapter, for the control signals, is constructed with a DB9 male plug, a DB9 female socket and a set of side entry vertical screw terminal strips. This allows easy access to the KPC-3+'s control output signals. The adapter unit is built into a DB9 "in-to-out" adapter housing. The male connector of the adapter is plugged into the KPC-3+'s female DB9 radio port connector (P1); and, any radio device normally used with the KPC-3+ is then plugged into the female DB9 socket on the Control Adapter.

KPC-3+ EXTERNAL CONTROL ADAPTER

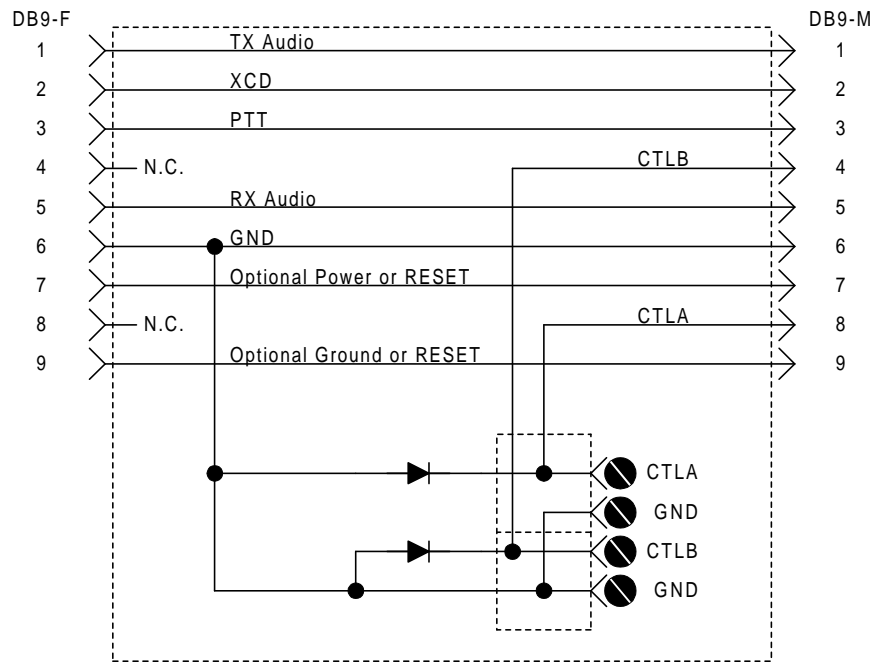

WA7ZVY 20041212.1

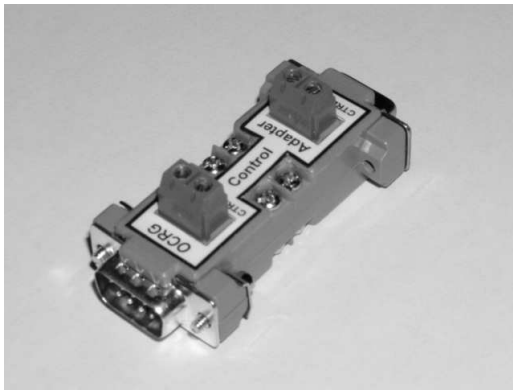

Control Breakout Adapter

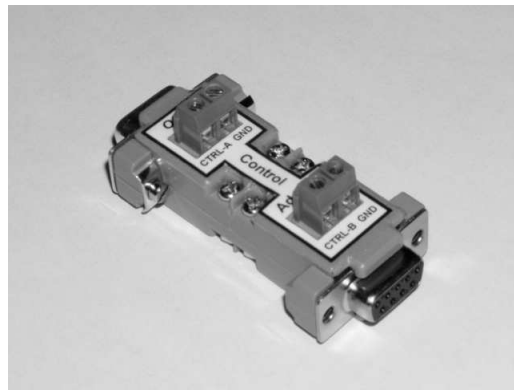

Control Breakout Adapter

14. PCB Layout for Attenuator Board

1:1 Bottom View

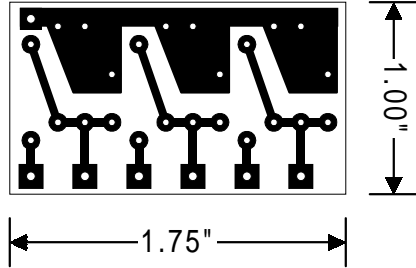

1:1 Mirrored Bottom View

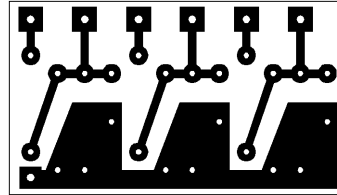

1:1 Top View

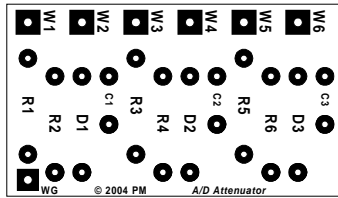

1:1 Mirrored Top View

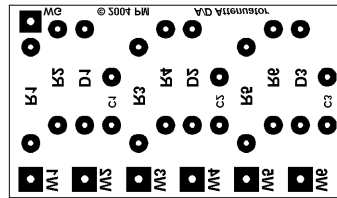

1:1 Composite View

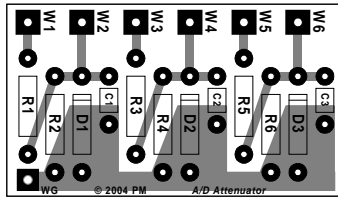

2:1 Bottom View

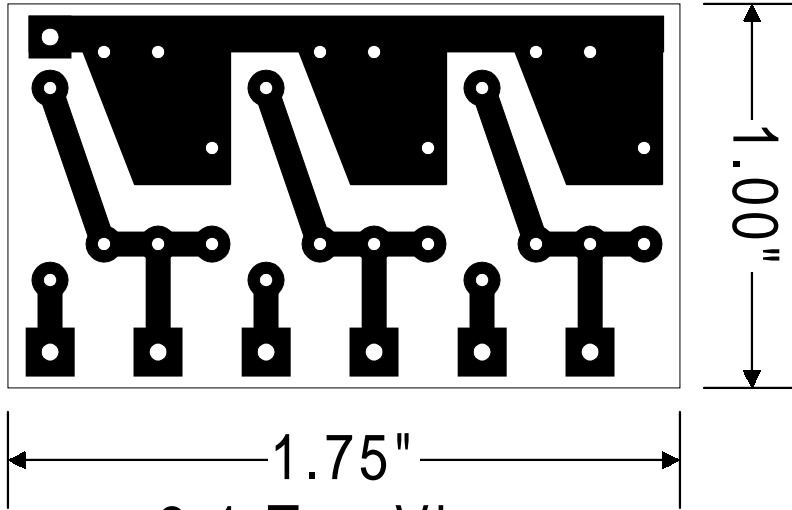

2:1 Top View

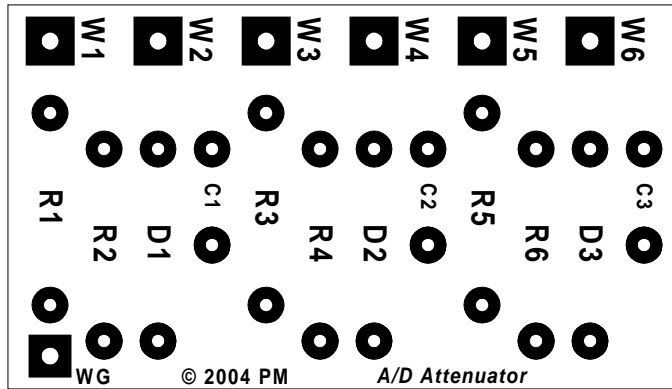

2:1 Composite View

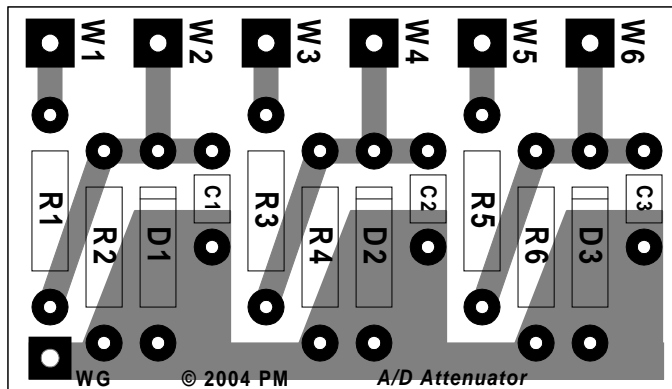

2:1 Mirrored Bottom View

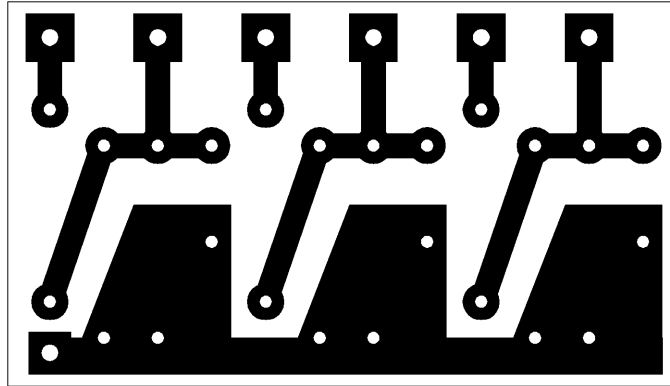

2:1 Mirrored Top View

